

A MANUAL OF PRACTICE FOR THE DESIGN OF PUBLIC IMPROVEMENTS
IN THE CITY OF BLOOMINGTON, ILLINOIS

Third Addition, July 2005

Adopted by the City Council of the City of Bloomington

July 25, 2005

COMPILED BY DEPARTMENT OF ENGINEERING

Douglas G. Grovesteen, P.E., Director of Engineering

A Manual of Practice for the Design of Public Improvements
in the City of Bloomington

CHAPTER 4 - Design and Construction Standards for Streets

4.01	Introduction.....	4-2
4.02	General Requirements	4-2
4.03	Right-of-way Dedication	4-3
4.04	Design Standards	4-4
4.05	Specifications and Special Provisions	4-5
4.06	Standard Details.....	4-7

4.01 INTRODUCTION

All lots in any subdivision, regardless of size, shall front on, and have access to, a street. When necessary, streets shall be included as part of the subdivision and shall be designed and constructed in accordance with this chapter.

4.02 GENERAL REQUIREMENTS

All subdivisions shall be designed so the proposed street system accomplishes the following:

- A. Conforms with the Comprehensive Plan of the City of Bloomington.
- B. Extends arterial and collector streets through the proposed subdivision.
- C. Locates and aligns local streets so that use by through traffic is discouraged.
- D. Avoids centerline offsets of less than 75 meters (250 feet) from other streets or roadways for local streets. For offsets from collector and arterial streets, a detailed engineering study may be required.
- E. Where the angle of deflection in horizontal center lines exceeds five degrees, a curve shall be inserted with a radius of not less than the following dimensions, depending on the classification of the street involved:
 - 1. Local streets where the deflection angle is 60 degrees or more - 20 meters (65 feet)
 - 2. All other - Per "Design and Environment Manual".
- F. So that not more than two streets intersect at any point and so that the angle of intersection of center lines is not less than 80 degrees nor more than 100 degrees.
- G. In R-1 and R-2 zoning districts so that cul-de-sacs do not exceed 365 meters (1200 feet) in length or have more than 15 lots fronting thereon, whichever imposes the more demanding standard and in R-3 and two-family zoning districts so that cul-de-sacs do not exceed 120 meters (400 feet) or have more than 8 lots fronting thereon, whichever imposes the more demanding standard.
- H. Encourage safe and efficient traffic flow and provide sufficient vehicular storage space for stopping and turning movements so as not to conflict with traffic at intersecting streets or driveway entrances.
- I. In residentially zoned areas, access to arterial or collector streets should be provided every 365 meters (1200 feet) to 550 meters (1800 feet) measured along the arterial or collector street.
- J. The minimum curb radius where two streets intersect shall be 7.6 meters (25 feet) to face of curb. For arterial, collector, and local commercial streets, curb radii shall be sufficient to accommodate the appropriate design vehicle in accordance with Illinois Department of Transportation "Design and Environment Manual".
- K. Cul-de-sac streets shall not be constructed "back to back." (Back yards on one cul-de-sac may not be adjacent to back yards of another cul-de-sac).
- L. Lots zoned R-1C or R-2 shall have a minimum 18 meter (60 feet) lot width measured at the building set back line if located on the bulb of a cul-de-sac street.

- M. Driveways shall not encompass more than 50% of the curb on the bulb of a cul-de-sac street.

4.03 RIGHT-OF-WAY DEDICATION

- A. All streets and roadways proposed within the confines of a subdivision shall be located in dedicated public or on private right-of-way as required by this section. All streets are considered public unless specifically stated that they are private on the preliminary plan and final plat.

- B. Interior Streets

- 1. **Public Streets.** Subdivisions shall be designed so all interior streets are located within dedicated public rights-of-way of the following minimum widths, depending on the street classification, the volume of traffic and the zoning of the abutting property (where side streets abut two or more zoning districts, right-of-way dedication shall be provided so as to meet the requirement of the more demanding zoning district):

Type of Street	R-1 and R-2 Zoning Districts	R-3 Zoning Districts	B, C, M and W Zoning Districts
Arterial			
Over 1200 DHV	29 m (96 ft)	29 m (96 ft)	29 m (96 ft)
Under 1200 DHV	26 m (86 ft)	26 m (86 ft)	27 m (90 ft)
Collector	24 m (80 ft)	24 m (80 ft)	27 m (90 ft)
Local	18 m (60 ft)	18 m (60 ft)	18 m (70 ft)
Cul-De-Sac (dia)	30 m (100 ft)	30 m (100 ft)	34 m (120 ft)
4 Lane w/median	30 m (100 ft)	30 m (100 ft)	30 m (100 ft)
Frontage Roads	18 m (60 ft)	18 m (60 ft)	18 m (60 ft)

- Expressway) In accordance with the Comprehensive Plan of the City of Bloomington
-) or the standards and requirements of the Federal, State, County
-) or Township authorities having jurisdiction, whichever has the
- Interstate) greater right-of-way width requirement.

- 2. Private Streets. Subdivisions shall be designed so all interior streets are located within dedicated right-of-way of the following minimum width:
 - a. Street without sidewalk: One meter (3 ft.) back of curb to one meter (3 ft.) back of curb
 - b. Street with one adjacent sidewalk: Back at sidewalk to one meter (3 ft.) back of curb.
 - c. Street with two adjacent sidewalks: Back of sidewalk to back of sidewalk.

- C. Exterior Streets--Subdivisions shall be designed so that the subdivider provides not less than one-half the right-of-way dedication required for a comparable interior street.

- D. Supplemental Dedication--where the street design requirements of this ordinance require the provision of turning lanes, turning radii, center median, traffic control devices or other installation which cannot be installed within the right-of-way otherwise required by this Code without the elimination or conflict between such features and other public improvements, the subdivider shall dedicate such additional right-of-way as is necessary to accommodate all such improvements.

4.04 DESIGN STANDARDS

- A. Street Width
Pavement width shall be based on street classification, the expected traffic volume and the zoning district (the more demanding standard shall apply) in accordance with the following minimums:

Street	Pavement Width (face to face of curb)	Median Width
Arterial		
Over 855 DHV	15.4 m (51 ft)	1.2 m (4 ft.)
495-855 DHV	14.1 m (47 ft)	0
Under 495 DHV	11.0 m (36 ft)	0
Collector		
Over 495 DHV	14.1 m (47 ft)	0
Under 495 DHV	11.0 m (36 ft)	0
Local		
	9.0 m (30 ft.)	0
Frontage Roads		
	9.0 m (30 ft)	0
Boulevards		
	2 @ 6.6 m (2 @ 22 ft)	3 m (10 ft)
One Way		
	7.2 m (24 ft)	0
Private Street		
R-1, R-2 Zoning	9.0 m (30 ft.)	
R-1, R-2 Zoning	7.2 m (24 ft.) (if no parking allowed)	
All other zoning	9.0 m (30 ft.)	

- B. Pavement Structure
Structural strength shall be based on street classification, the expected traffic volume and designed in accordance with current:
1. Illinois Department of Transportation "Design and Environment Manual"
 2. Illinois Department of Transportation "Highway Standards".
 3. Illinois Department of Transportation "Standard Specifications for Road and Bridge Construction".

Local streets shall be constructed with a minimum of 250 mm (10 inches) of compacted crushed aggregate and 75 mm (3 inches) of bituminous concrete surface, or 150 mm (6 inches) of Portland Cement Concrete, installed in accordance with "Standard Specifications For Road And Bridge Construction" in accordance with the following design and construction standards and specifications:

- C. Cul-de-Sac Terminus
Cul-de-sac terminus shall have a minimum diameter measured face-of-curb to face-of-curb of 24 m (80 feet) in areas zoned residential and 30 m (100 feet) in all other areas.
- D. Vertical Gradients
Differing connecting street gradients shall be connected with vertical curves. The “Design and Environment Manual” shall govern all vertical curve computations, except when the algebraic difference of the gradient is less than one (1) percent a 15 m (50 foot) vertical curve length shall be utilized . Desirable street gradients shall be not less than a minimum of 0.50% (five tenths of one percent). In no case shall the street gradient be less than 0.40%, or more than 8.0%.
- E. Curb and Gutter
All streets which are to be publicly maintained shall have curb and gutter.
1. Curb and gutter shall be Type B 15.45 (B-6.18) in accordance with “Highway Standards” and installed in accordance with the “Standard Specifications of Road and Bridge Construction”.
 2. All curb and gutter shall be designed so as to facilitate persons using wheelchairs to travel freely and without assistance by providing at each crosswalk a ramp with non-slip surface so that the sidewalk and street blend to a common level. Such ramp shall be designed and constructed in accordance with the “Highway Standards”.
- F. Trench Backfill
Any excavation in a proposed street shall be back filled with trench backfill.

4.05 SPECIFICATIONS & SPECIAL PROVISIONS

All streets and curb and gutter shall be constructed in accordance with all applicable sections of the “Standard Specifications for Road and Bridge Construction” for the Illinois Department of Transportation, the current edition as then modified, supplemented and amended by this Manual or the Director of Engineering and Water. These modifications, amendments and amplifications have been provided in this Chapter of the Manual.

Street Special Provisions

Curb marking of Water and Sewer Services: At the time the curb and gutter is poured, the contractor shall permanently mark the top of the curb with an “S” for sewer and “W” for water to mark location of said services.

Adjustment of Frame of Grate: Final grade for all manhole castings will be determined after the curb and gutter has been poured and the sub grade and/or base has been constructed. Final adjustment of the frame and grate shall be made in the following manner: After the curb and gutter has been poured and the base constructed the final elevation will be determined by the Director of Engineering & Water. The frame and grate will be adjusted to this elevation in accordance with the “Standard Specifications For Road And Bridge Construction”. Any material disturbed while adjusting the frame and grate will be disposed of and all fill made with lean concrete. A maximum of 200 mm (8 inches) of adjusting rings shall be allowed.

Coarse Aggregate: Shall comply with “Standard Specifications For Road And Bridge Construction”.

Combination Concrete Curb and Gutter: Concrete curb and gutter shall be sawed or scored at intervals coinciding with the joint intervals of the adjoining pavement. The minimum joint depth for the gutter shall be 50 mm (2 inches), and 25 mm (1 inch) for the curb. The curb and gutter may be jointed instead of sawed provided the stated joint depths are obtained. If the curb and gutter is adjacent to bituminous pavement it shall be jointed at 4.5 m (15 foot) intervals.

The sawing of the curb and gutter shall commence within four (4) hours of the start of the pour unless otherwise directed by the Director of Engineering And Water. Sawing shall continue until all joints are completed.

Asphaltic type expansion joints 25 mm (1 inch) thick shall be placed at all P.C.'s, P.T.'s and R.P.C.'s and at maximum 150 meter (500') intervals.

Test Rolling of Sub grade and Base Course: The contractor will provide at his own expense a loaded truck and test roll the compacted earth sub grade in the presence of the Director of Engineering and Water or his designee before any sub-base, base, or surface is placed. The truck shall be loaded as follows: 12,000 kg (27,000 lbs) on two axles and 20,000 kg (45,000 lb.) on three axles, plus or minus ten per cent.

The truck shall make one pass over the entire length of each traffic lane to be constructed. Areas which show rutting, cracking or rolling will not be accepted. The contractor will recompact and/or reconstruct the sections that fail and test role again for acceptance.

When bituminous surface courses or concrete pavement are to be placed over an aggregate base, the base shall be test rolled prior to placement of the surface course or pavement.

Portland Cement Concrete Pavement: The distance between sawed transverse joints shall not be greater than 30 times the thickness of the pavement apart or a maximum of 6 meters (20 ft.) and shall conform with the details in the plans. All equipment and labor required to perform the necessary jointing operation shall be available to begin sawing no later than four (4) hours after the paving operation begins, unless excess raveling occurs. The contractor shall provide the necessary equipment and labor needed to complete the sawing at the same rate per longitudinal foot as the paving operation.

The contractor shall stop the paving operation at 4:30 P.M. unless approved otherwise by the Director of Engineering & Water. Sawing shall continue at the same rate as stated above until the sawing is complete or the pavement has stopped curing.

Trucks and mixer trucks will be allowed to operate on the sub grade; however, should the sub grade show any signs of distress, all operations will cease until these items are corrected to the satisfaction of the Director of Engineering & Water. Curb and gutter formed monolithically with the pavement will be permitted provided the slip form paving equipment used is approved by the Director of Engineering.

Final finish shall be Type B (artificial turf drag) as described in "Standard Specifications For Road And Bridge Construction".

Portland Cement Concrete Driveway Pavement: Pavement shall be a minimum of 150 mm (6 inches) in depth. Sawed transverse and longitudinal joints shall conform to the following table:

<u>Driveway Width at Widest Point</u>	<u>No. of Longitudinal Saw Cuts</u>
0 M - 4 M (0 -12 ft)	0
4 M - 8 M (12 ft - 24 ft)	1
8 M - 12 M (24 ft - 36 ft)	2

<u>Maximum Driveway Length</u>	<u>No. of Transverse Saw Cuts</u>
0 M - 4 M (0 - 12 ft)	0
4 M - 8 M (12 ft - 24 ft)	1
8 M - 12 M (24 ft - 36 ft)	2

The sawed joints shall be spaced evenly throughout the driveway. The joints shall be 3 mm (1/8 inch) wide with a minimum depth of one-fourth the depth of the pavement and sealed with the same material and in the same manner as Portland Cement Concrete Pavement.

20 mm (3/4 inch) thick expansion joints shall be placed between driveway pavement and sidewalks and between driveway pavement and curb and gutter.

4.06 STANDARD DETAILS

<u>Standard Drawing</u>	<u>Title</u>
A	Typical Pavement Section - Minor Street
B	Standard Joint Details
C	Barrier Curb & Gutter Detail
D	Typical Intersection Joint Detail
E	Typical Cul-de-sac Joint Detail
F	Driveway Entrance Detail
G	Typical Monolithic PCC Pavement Section - Minor Street

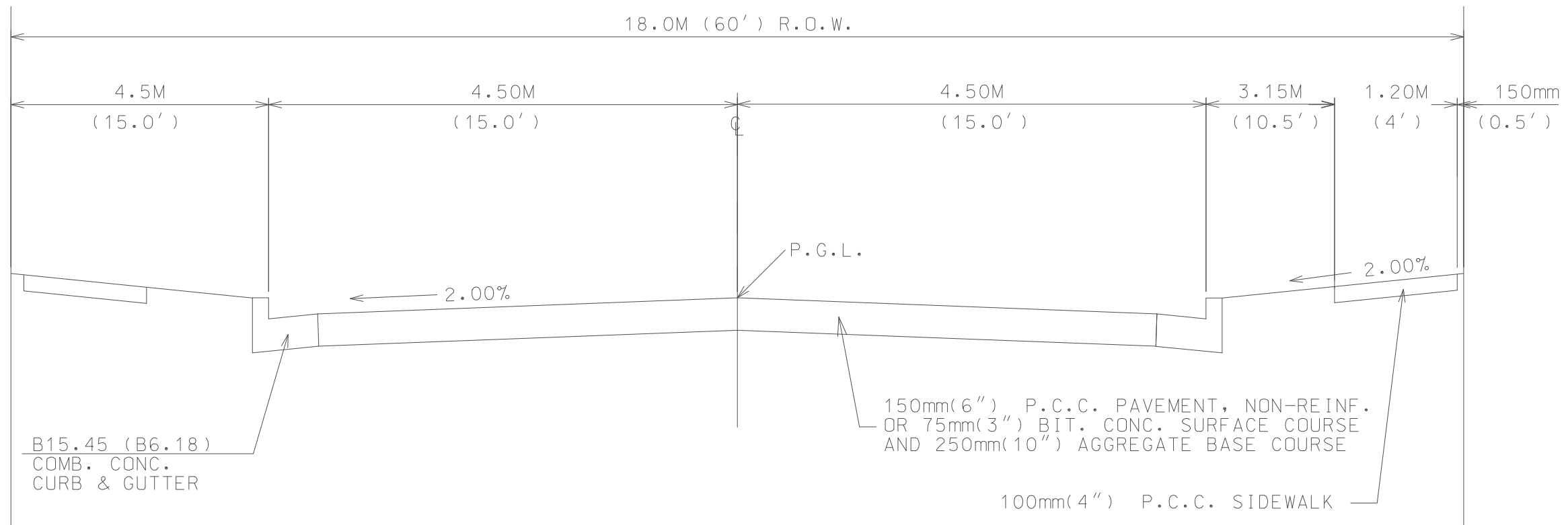

TYPICAL PAVEMENT SECTION - MINOR STREET



BY :
APPROVED DATE :

DESIGN BY : DOUG GROVESTEN
REVISED :
TYPICAL PAVEMENT SECTION - MINOR STREET
STANDARD DETAIL 4.06A

SHEET
| OF |

- When a joint falls within 5 ft. of or contacts basins, manholes, or other structures, shorten one or more panels either side of opening to permit joint to fall on round structures and at or between corners of rectangular structures.
- All transverse joints must extend through curbs and must be continuous across pavement. Asphaltic expansion joints, 25mm(1inch) thick shall be placed at all P.C.'s, P.T.'s, and R.P.C.'s and at maximum 150M(500') intervals.
- The distance between sawed traverse joints shall not be greater than 30 times the thickness of the pavement apart or a maximum of 6M(20').
- Sawed joints shall be sealed with hot poured material meeting the requirements of tentative specification for concrete joint sealer hot poured elastic type ASTM designation: D3405 or sealed with a cold applied ready-mixed concrete joint sealing compound meeting the requirements of Article 1050.01.
- Transverse construction joint must be at a contraction or expansion joint.
- All saw joints, longitudinal or transverse shall be nonreinforced.
- For rigid bases (CAM), the expansion joint material need not extend 25mm (1inch) below the pavement.

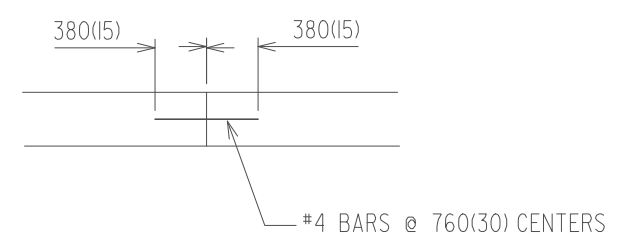
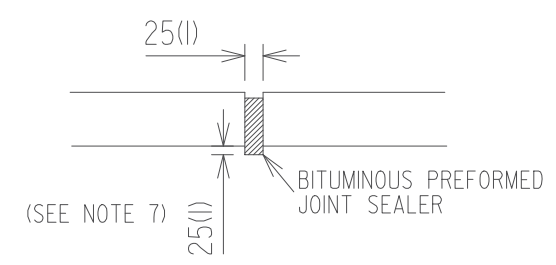
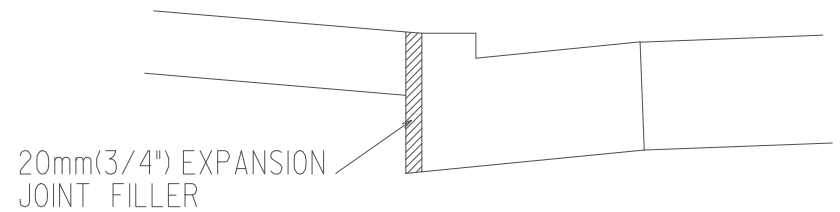
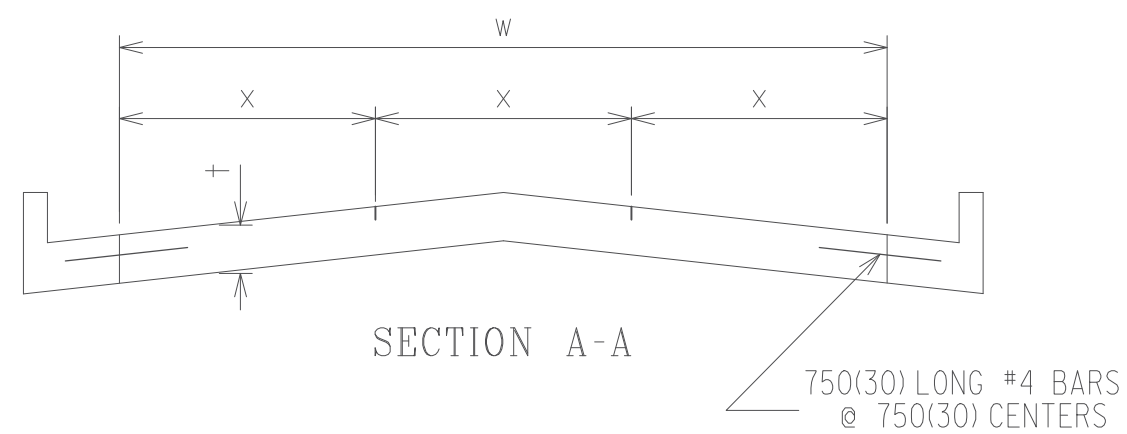
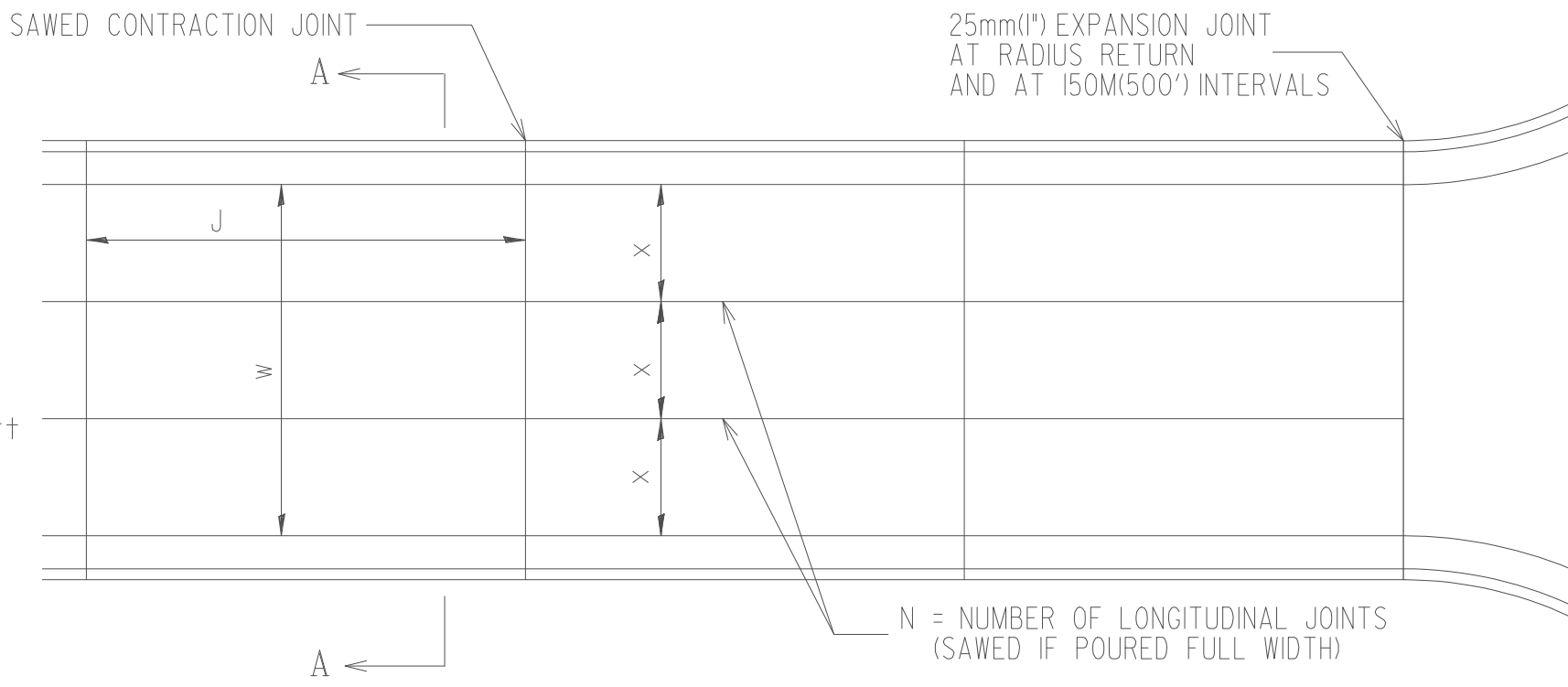

w	N	x
6.7M (22')	1	3.4M (11')
7.0M (23')	1	3.5M (11.5')
7.3M (24')	1	3.7M (12')
8.2M (27')	2	2.7M (9')

w	N	x
10.1M (33')	2	3.4M (11')
10.7M (35')	2	3.6M (11.75')
12.5M (41')	3	3.1M (10.75')
13.4M (44')	3	3.4M (11')

w	N	x
14.0M (46')	3	3.5M (11.5')
14.6M (48')	3	3.7M (12')

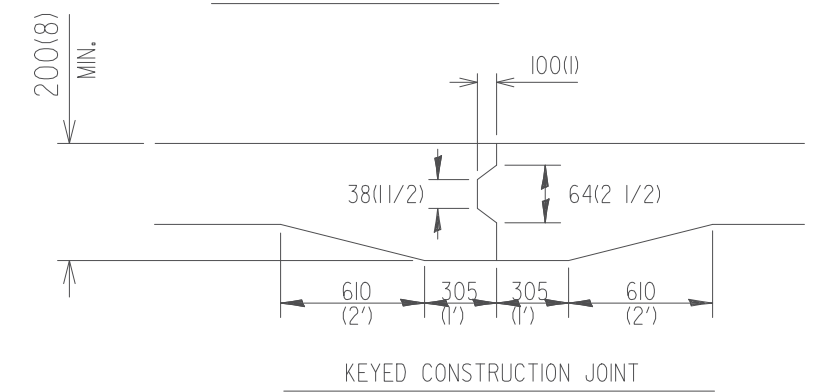
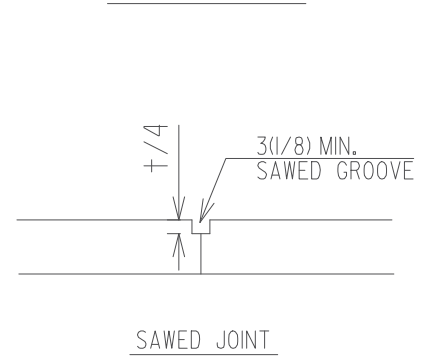

COMBINATION CONCRETE CURB AND GUTTER TYPE B 15.45 (B 6.18)

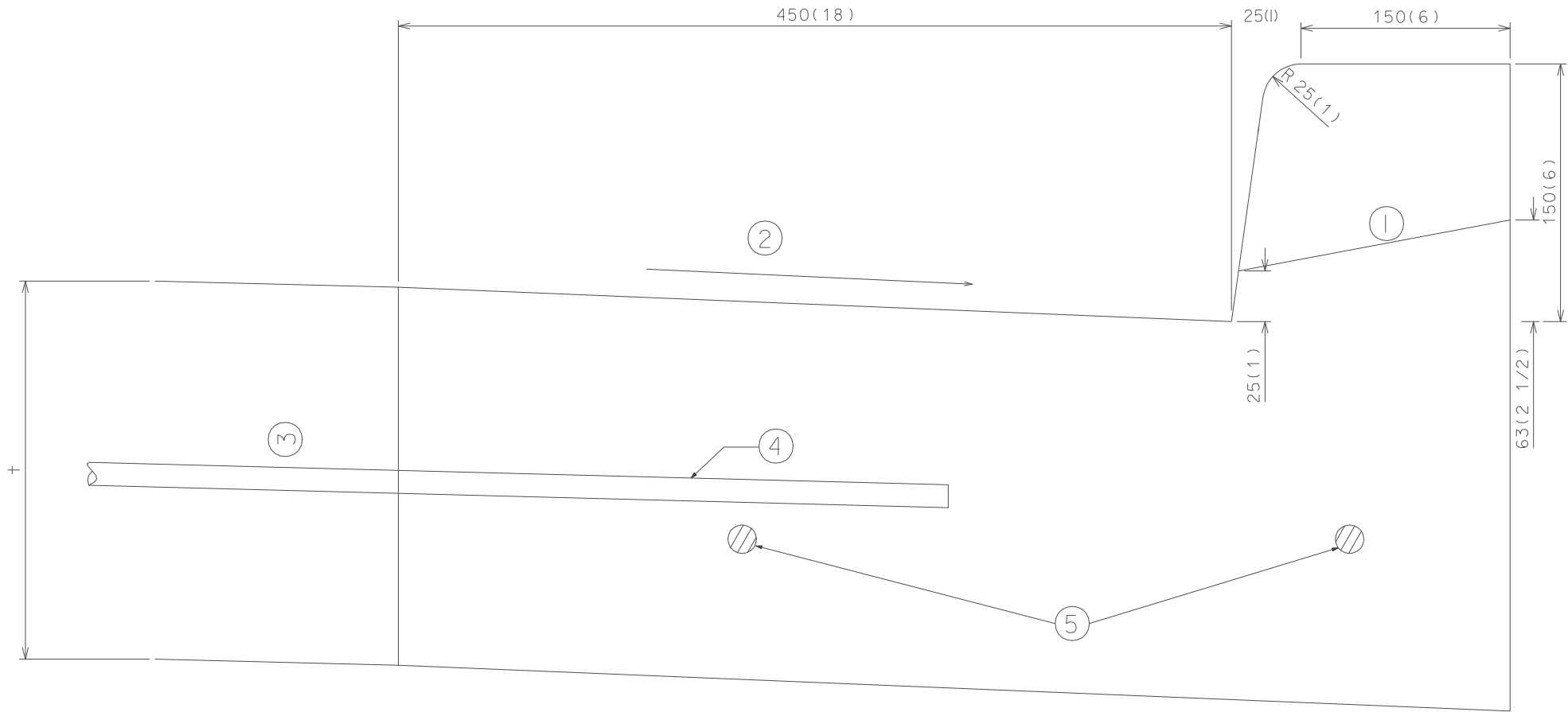

GENERAL NOTES

- ① DEPRESS AT DRIVEWAYS
- ② SLOPE 62mm/M (3/4 IN/FT) EXCEPT AT INTERSECTIONS
- ③ X = 200(8) OR DEPTH OF PAVEMENT WHEN ADJACENT TO P.C.C. PAVEMENT, WHICHEVER IS GREATER.
X = 200(8) WHEN ADJACENT TO P.C.C., AGGREGATE, BITUMINOUS OR BRICK BASE COURSE.
- ④ 760mm(30") LONG #4 REBARS AT 760(30) SPACING (USED ONLY WHEN ADJACENT TO P.C.C. PAVEMENT OR P.C.C. BASE)
- ⑤ #4 REBARS CONTINUOUS THROUGHOUT (USED ONLY WHEN ADJACENT TO BITUMINOUS, BRICK OR AGGREGATE BASE)

† = THICKNESS OF PAVEMENT.

ALL DIMENSIONS ARE IN MILLIMETERS (INCHES) UNLESS OTHERWISE SHOWN.



BY :
APPROVED DATE :

DESIGN BY : DOUG GROVESTEN REVISED :
BARRIER CURB & GUTTER DETAIL
STANDARD DETAIL 4.06C

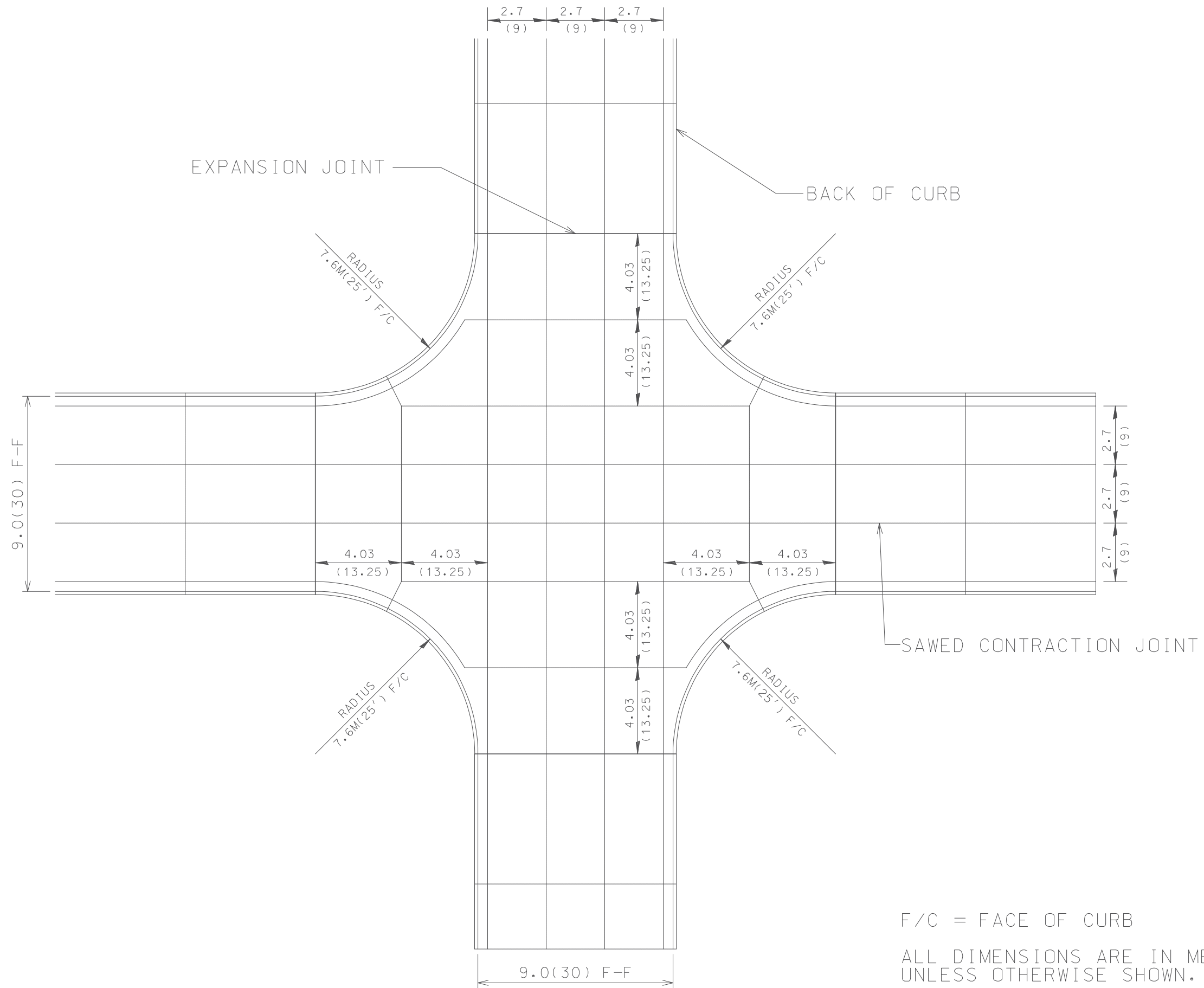

F/C = FACE OF CURB

ALL DIMENSIONS ARE IN METER (FOOT)
UNLESS OTHERWISE SHOWN.



DESIGN BY : DOUG GROVESTEN
REVISER :
APPROVED DATE :

TYPICAL INTERSECTION JOINT DETAIL
STANDARD DETAIL 4.06D

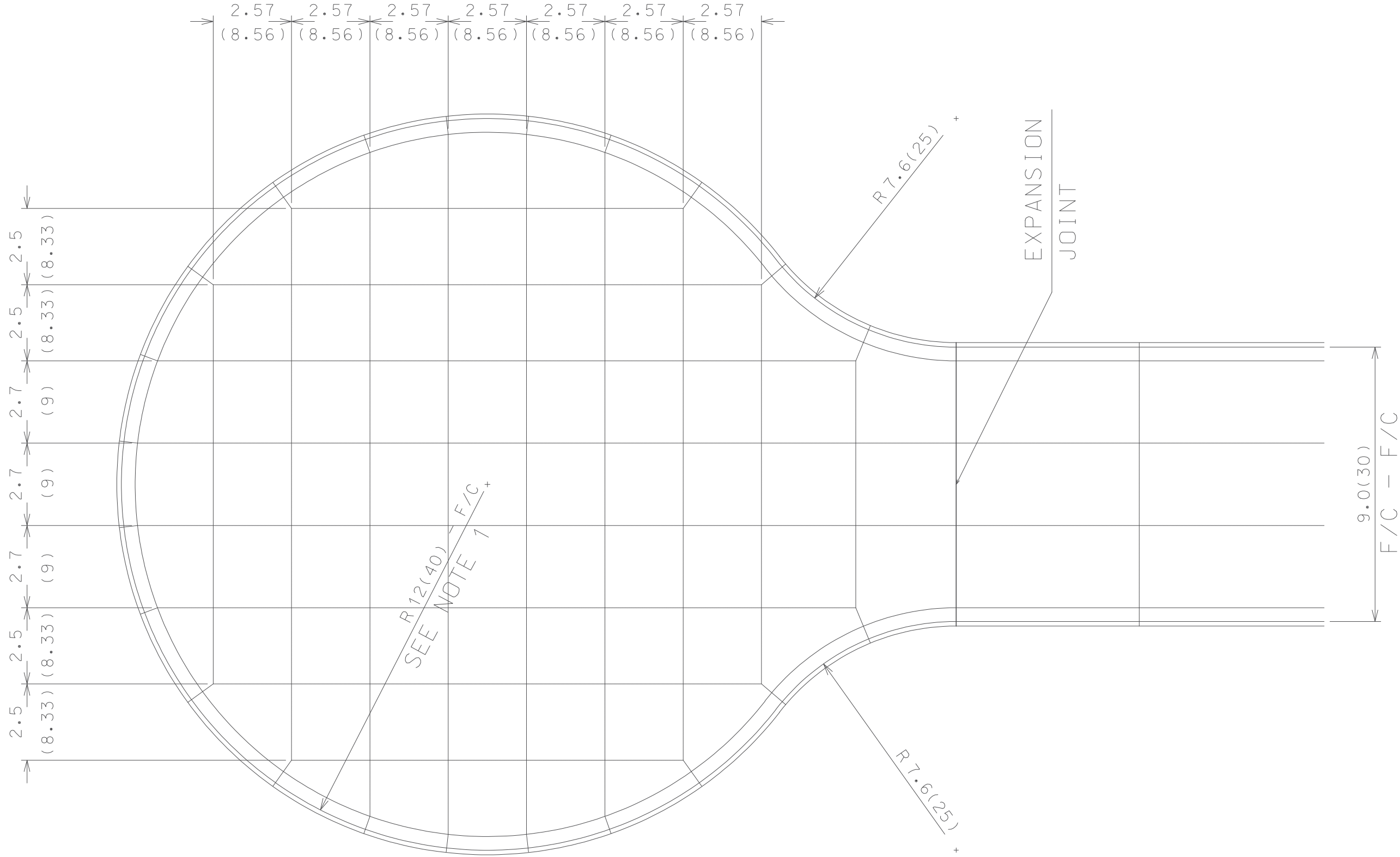

1. Cul-de-sac terminus shall have a minimum diameter measured face-of curb to face-of-curb of 24 meters (80 feet) in areas zoned residential and 30 meters (100 feet) in all other areas.
2. All dimensions on this sheet are in meters (feet) unless otherwise noted.
3. Sawed joint dimensions shown are for a typical 30M(100') dia. cul-de-sac.



DESIGN BY : DOUG GROVESTEEN
REVISOR :
APPROVED DATE :

TYPICAL CUL-DE-SAC JOINT DETAIL
STANDARD 4.06E

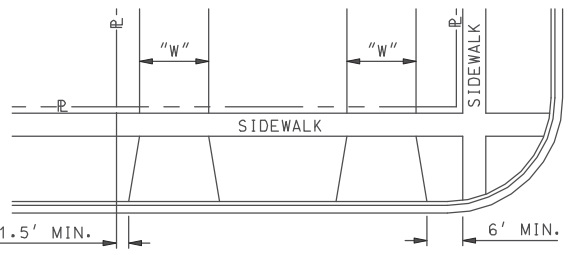
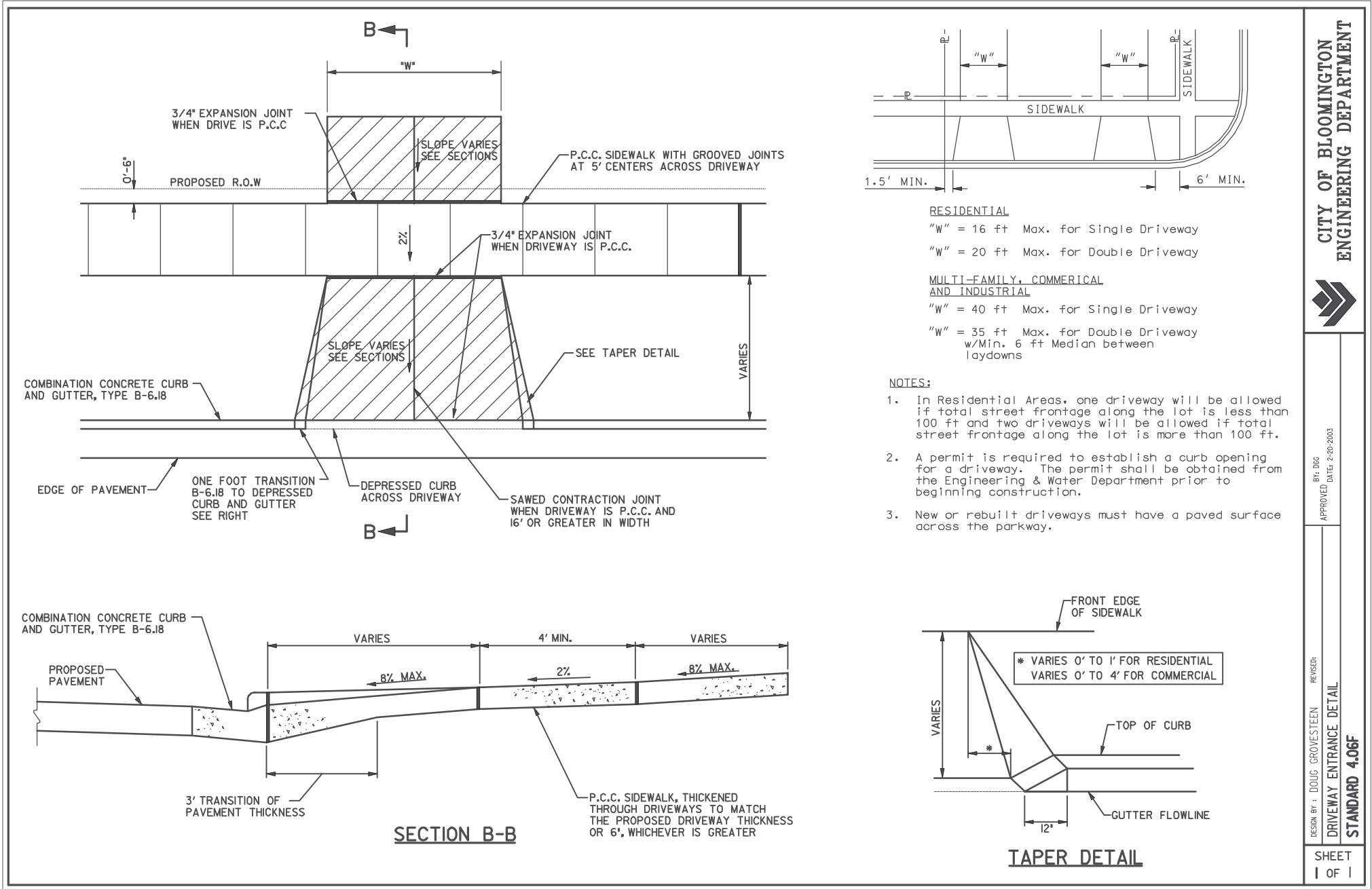

RESIDENTIAL
 "W" = 16 ft Max. for Single Driveway
 "W" = 20 ft Max. for Double Driveway

MULTI-FAMILY, COMMERCIAL AND INDUSTRIAL
 "W" = 40 ft Max. for Single Driveway
 "W" = 35 ft Max. for Double Driveway
 w/Min. 6 ft Median between laydowns

- NOTES:**
1. In Residential Areas, one driveway will be allowed if total street frontage along the lot is less than 100 ft and two driveways will be allowed if total street frontage along the lot is more than 100 ft.
 2. A permit is required to establish a curb opening for a driveway. The permit shall be obtained from the Engineering & Water Department prior to beginning construction.
 3. New or rebuilt driveways must have a paved surface across the parkway.

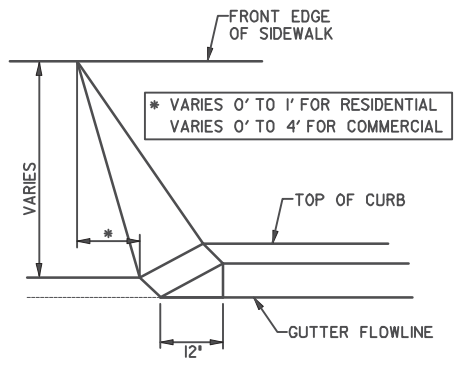

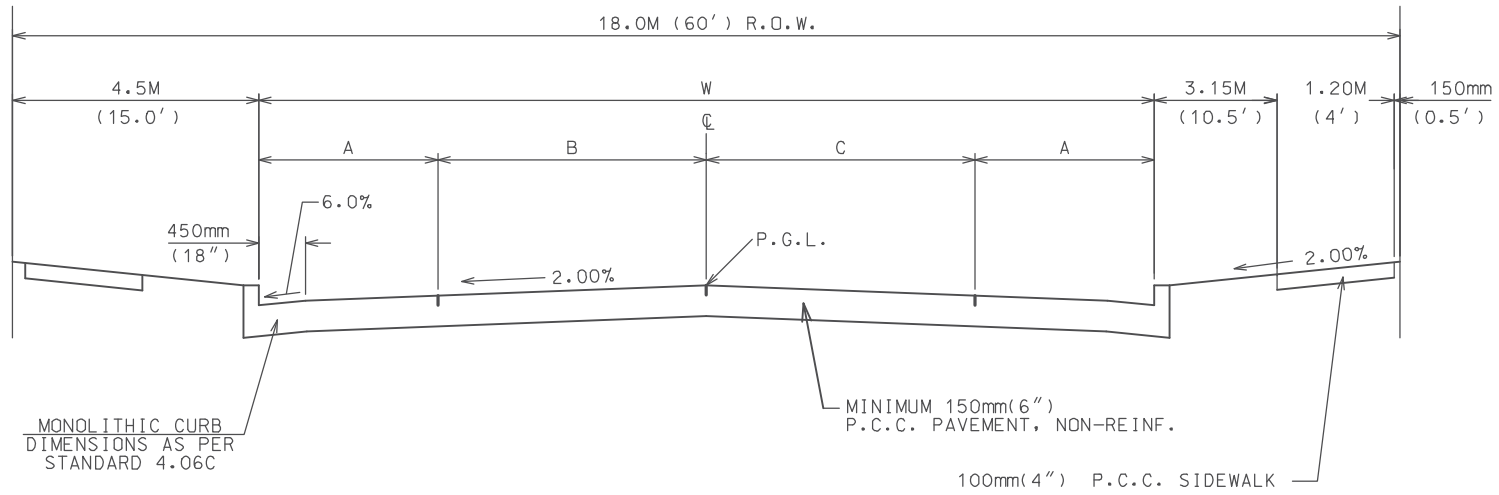

W	N	A	B	C
7.3 M (24')	2	1.8 M (6')	3.7 M (12')	0
7.9 M (26')	2	2.1 M (7')	3.7 M (12')	0
9.1 M (30')	3	1.8 M (6')	2.75 M (9')	2.75 M (9')
11.0 M (36')	3	1.8 M (6')	3.7 M (12')	3.7 M (12')

TYPICAL MONOLITHIC P.C.C. PAVEMENT SECTION

